



X-LED SPOTLIGHT HEAD INSTALLATION INSTRUCTIONS

A460: 8849
Orig. Date: 11/14/15
Page 1 of 2
Rev. A Date: 11/04/16

Please read all the instructions carefully before proceeding with replacing old spotlight head with new X-LED spotlight head.

I. Remove Old Spotlight Head

1) Remove Wedge Pin (Figure 3)

Using a 3/32" pin-removal punch (see Figure 2) and a hammer to knock out *Wedge Pin* from the side as shown in Figure 3.

Wedge Pin has a slight taper, one end is slightly bigger than the other end as shown in Figure 8.

So, it is important to knock *Wedge Pin* from side as shown in Figure 3.

2) Remove Old Spotlight Head (Figure 4)

Holding *Spotlight Head* with one hand, tapping on *Head Housing* with a Rawhide Mallet or a Rubber Hammer to remove *Spotlight Head* from *Head Housing*.

To prevent *Head Housing* from damage, do not use steel hammer!

3) Keep Rod Gear Fully Seated (Figure 5)

Rod Gear has to be kept fully seated inside *Head Housing* during installing the new X-LED spotlight head. Otherwise, the new head cannot be installed fully into *Head Housing*, and parts may be damaged.



Figure 1: Rawhide Mallet



Figure 2: 3/32" Pin-Removal Punch

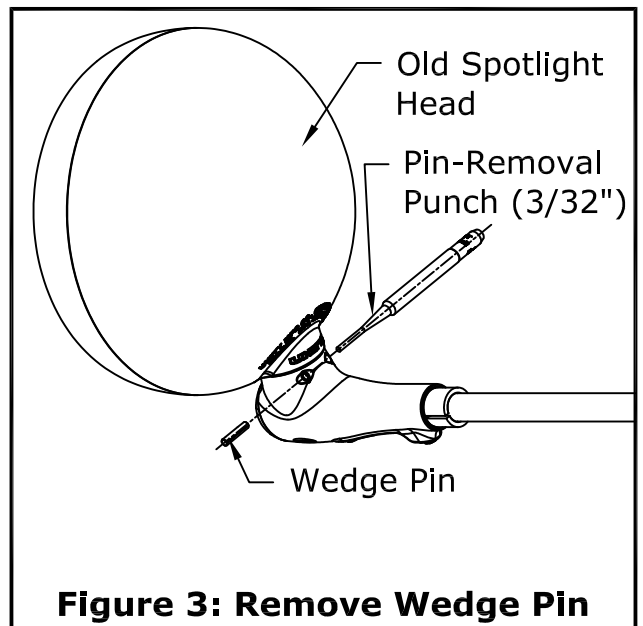

Figure 3: Remove Wedge Pin

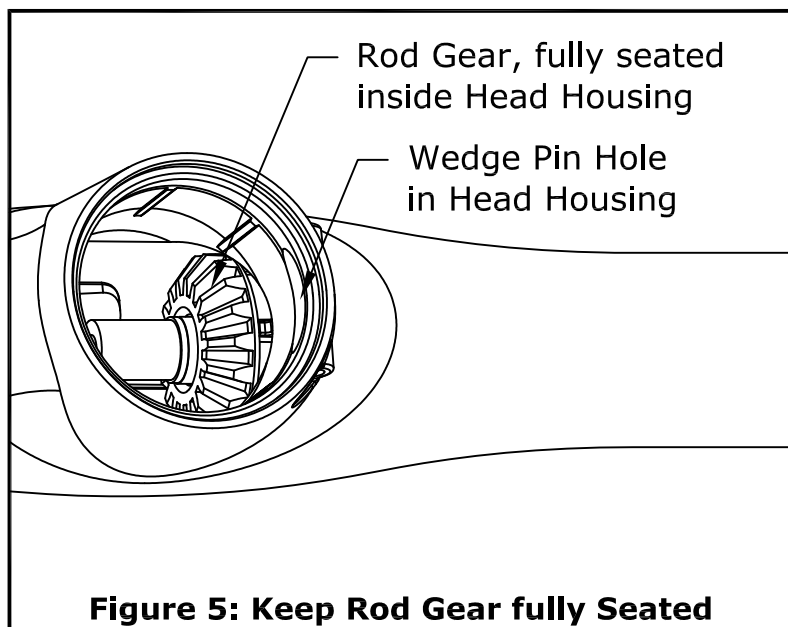

Figure 5: Keep Rod Gear fully Seated

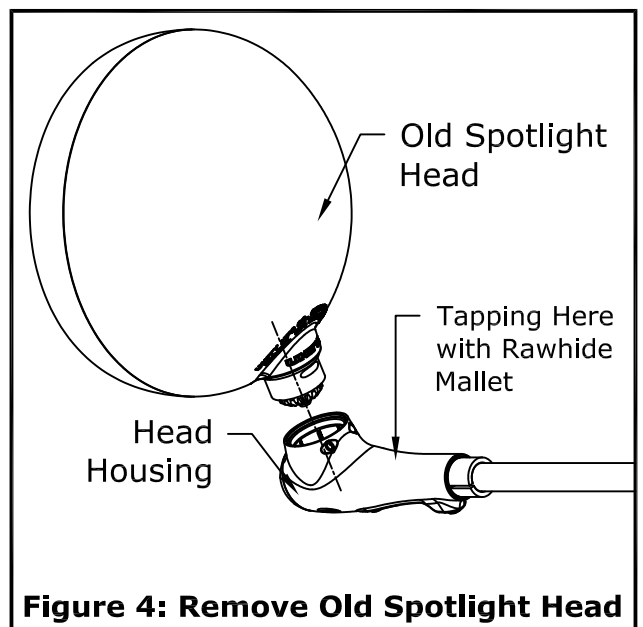

Figure 4: Remove Old Spotlight Head



X-LED SPOTLIGHT HEAD INSTALLATION INSTRUCTIONS

A460: 8849

Orig. Date: 11/14/15

Page 2 of 2

Rev. A Date: 11/04/16

II. INSTALL NEW X-LED SPOTLIGHT HEAD

1) Check Bushing and Contact Pin (Figure 6)

Check the bushing orientation. If necessary, rotate *Bushing* so that its groove is facing up as shown in Figure 6.

Check *Contact Pin*. If *Contact Pin* is missed or pushed out by *Contact Spring*, stop and do not proceed with installation. Contact Unity.

2) Install New Head (Figure 7)

- A) Align the groove on *Bushing* with the hole on *Head Housing* with their axes parallel to each other.
- B) Insert *Bushing* into *Head Housing*. Tap on *Head Housing* with a Rawhide Mallet until *Bushing* is fully seated with the groove axis coincident with the hole axis.

3) Install Wedge Pin (Figure 8 & Figure 9)

- A) *Wedge Pin* has three small grooves. They are deeper and wider at the larger end. Insert the smaller end into the hole on *Head Housing*.
- B) Drive *Wedge Pin* with a punch until it is fully inserted with its end flush with the boss on *Head Housing*.

4) Test X-LED Spotlight

- A) Turn *Spotlight* on and off a few times.
- B) Rotate *Spotlight* head 360° clockwise and then counterclockwise with light on.
- C) Turn *Spotlight* off and put it at *Park Position*.

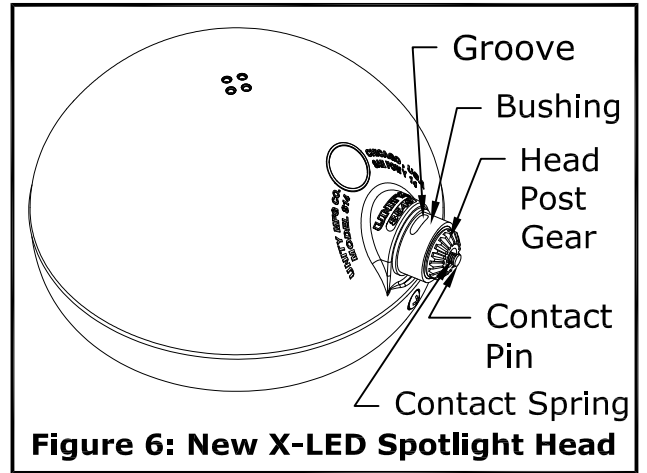

Figure 6: New X-LED Spotlight Head

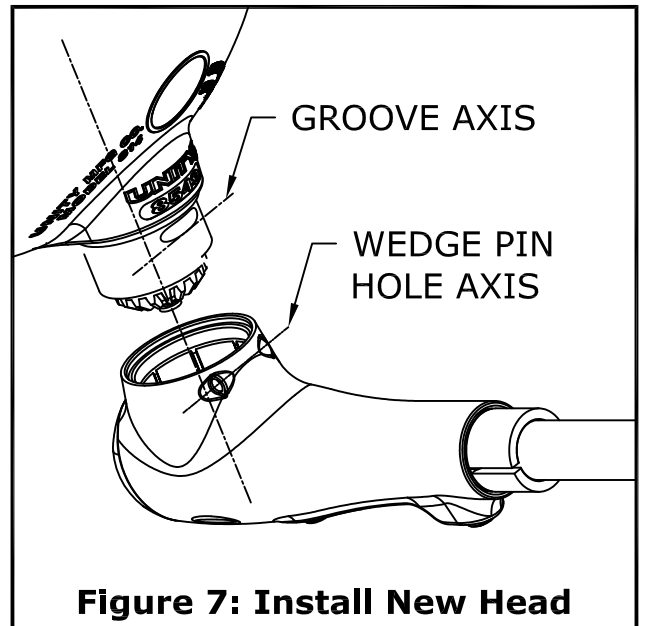

Figure 7: Install New Head

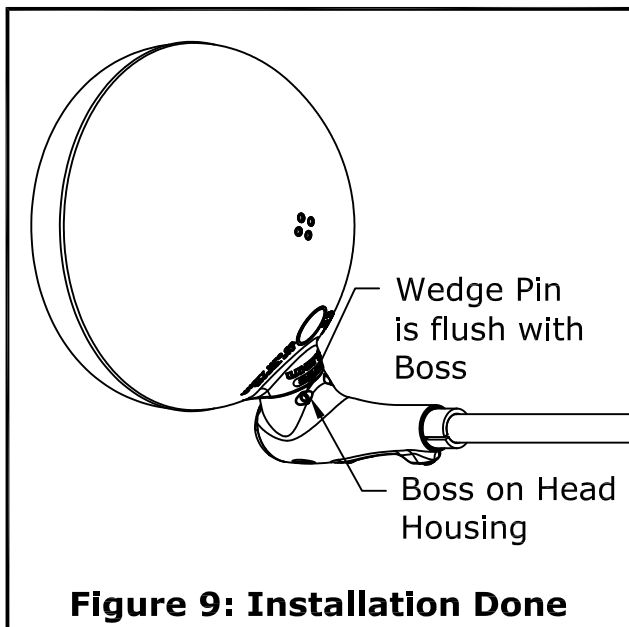

Figure 9: Installation Done

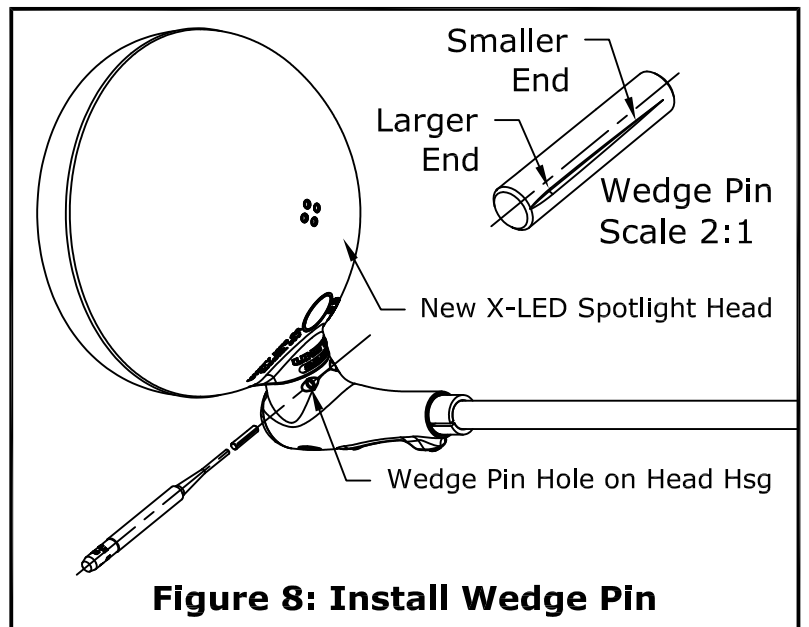

Figure 8: Install Wedge Pin